

EF39FMPF Series



39"

FEATURES

Ideal for both indoor and outdoor applications in commercial or residential settings and crafted from durable 304 stainless steel, it is built to withstand the elements, ensuring long-lasting performance.

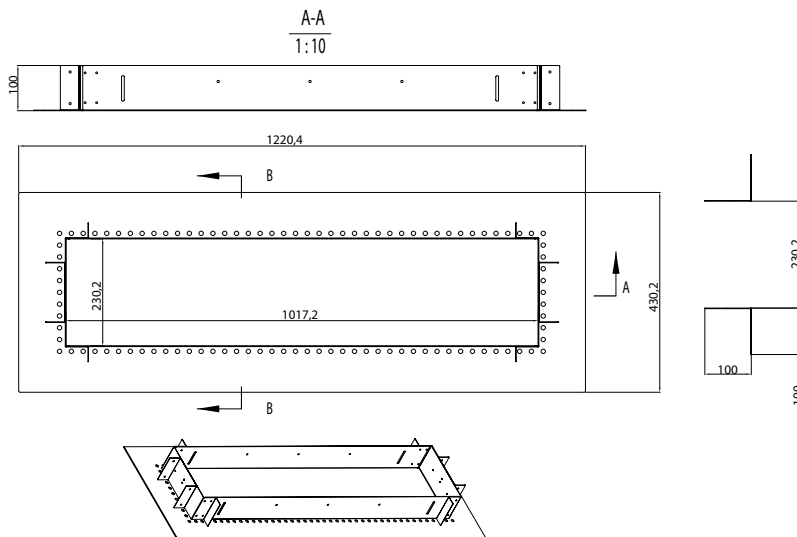

DESCRIPTION	CODE	FINISH	CODE	CUSTOMIZATION	CODE
39" Flush Mount Kit	EF39FMPF	BLACK	B	MARINE GRADE STAINLESS STEEL	316-SS
		STAINLESS STEEL	S		
		WHITE	W	CUSTOM COLOR	RAL#

• For custom manufacturing contact sales

Project _____

Type _____

Date _____

Address _____

Company _____

- Compatible with all EF heaters
- Designed for commercial and residential applications.
- Available in a standard 304 Stainless Steel, Black, White or Marine Grade 316 Stainless Steel finish
- ETL Listed



SPECIFICATIONS

SERIES	SERIES EF39FMPF
FINISH	Black, Stainless Steel, White, Custom
CONSTRUCTION	Stainless Steel (Standard: 304 SS; Optional: 316 Marine Grade SS)
COMPATIBLE MODELS	EF15, EF20, EF25, EF40, EF50 SERIES (39" HEATERS)
MOUNTING TYPE	Recessed
INTERNAL MEASUREMENTS	L= 40.04 in (1017.20mm) W= 9.06 in (230.2mm)
EXTERNAL MEASUREMENTS	L= 48.05 in (1220.40mm) W= 16.94 in (430.20mm)
WEIGHT	13.1 lbs
WARRANTY	3 years
ACCESSORIES	1x 4ft High Temperature Whip 4 x "L" Brackets & Screws 3 x High Temperature Murette

39" FLUSH MOUNT FRAME

- To accommodate a 39-inch heater, the finished opening should measure 43 3/4 x 12 inches.

